



SPE 90201

## Developing Vertical Column Induced Gas Flotation for Floating Platforms Using Computational Fluid Dynamics

Chang-Ming Lee, SPE, and Ted Frankiewicz, SPE, NATCO Group, Inc.

Copyright 2004, Society of Petroleum Engineers Inc.

This paper was prepared for presentation at the SPE Annual Technical Conference and Exhibition held in Houston, Texas, U.S.A., 26–29 September 2004.

This paper was selected for presentation by an SPE Program Committee following review of information contained in a proposal submitted by the author(s). Contents of the paper, as presented, have not been reviewed by the Society of Petroleum Engineers and are subject to correction by the author(s). The material, as presented, does not necessarily reflect any position of the Society of Petroleum Engineers, its officers, or members. Papers presented at SPE meetings are subject to publication review by Editorial Committees of the Society of Petroleum Engineers. Electronic reproduction, distribution, or storage of any part of this paper for commercial purposes without the written consent of the Society of Petroleum Engineers is prohibited. Permission to reproduce in print is restricted to a proposal of not more than 300 words; illustrations may not be copied. The proposal must contain conspicuous acknowledgment of where and by whom the paper was presented. Write Librarian, SPE, P.O. Box 833836, Richardson, TX 75083-3836, U.S.A., fax 01-972-952-9435.

### Abstract

Vertical column flotation technology has been developed specifically for service on floating platforms. The technology was developed using a combination of Computational Fluid Dynamics (CFD) simulation and physical testing. The time and cost to develop the new technology was substantially reduced through the use of CFD simulation. The development program culminated in the installation and successful operation of a 10,000 barrels of water per day (BWPD) column flotation unit on a spar in the Gulf of Mexico.

CFD simulations were used to optimize the distribution of process fluids and gas bubbles in the column flotation cell and to define a strategy for skimming oil from the flotation cell while the unit was in motion on a floating platform. The result was a column flotation unit design that sweeps each volume of produced water with 150 – 300 micron gas bubbles 400 – 700 times per minute during a 4-minute contact time and permits effective oil skimming even in rough seas. Field performance data is presented for the column flotation cell that is operating successfully on a spar in the Gulf of Mexico.

### Introduction and Background

A common configuration for water treatment systems on offshore platforms is the use of deoiling hydrocyclones followed by a degassing or skim vessel. More recently, the use of flotation has replaced the latter as flotation can be far more effective at removing oily contaminants from produced water. However, many platforms do not have space for horizontal flotation vessels and sloshing, generated by the motion of floating platforms (FPSO's, Spars, etc.) makes the operation of many horizontal flotation vessels difficult in all but the calmest sea states.

In the 1990's, single-cell column flotation was introduced to reduce the space required for flotation cells and to provide a configuration that was suitable for use on floating platforms.

At least one major oil company deployed a number of their internally developed column flotation units with only modest success. Commercially available designs were reviewed as the starting point for development of a new design for vertical column flotation technology. This internal review, along with Computational Fluid Dynamics (CFD) simulations, identified the following key issues for the successful performance of column flotation:

- Minimizing net downward water flow velocity
- Provision of coalescence assistance to grow oily contaminants particle size
- Improved distribution of inlet water
- Uniform and reliable distribution of flotation gas
- Minimizing internal recirculation zones that by-pass oily water around swarms of rising gas bubbles
- Elimination of break-out gas slugs to prevent the upsetting of the oil skimming process
- Control of the oil/water skimming in the flotation cell during sloshing induced by movement of the host platform
- Elimination of short-circuiting to the outlet nozzle.

To address these issues, CFD simulations were conducted to define the means required to reduce or eliminate the negative impact of the above-listed factors. A technology development program and a series of physical tests were conducted to verify the predictions of the simulations and to test the performance of proposed solutions to the identified problems. This sequence was repeated as necessary to correct design deficiencies uncovered by the physical test program and to verify improvements to the flotation cell design.

### Computational Fluid Dynamics Simulations

Computational fluid dynamics is a powerful diagnostic and design tool that can be used to identify and visualize product design flaws and to develop improvements.<sup>1</sup> Design variables for column induced gas flotation (IGF) development included the configuration of the gas eductor, the Gas Volume Fraction (GVF) introduced into the flotation cell through the eductor, the size of bubbles in the eductor's gas/water mixture, the geometry of internals to improve gas bubble distribution within the cell, the geometry of the oily water inlet device, and the baffle system to control oil skimming as water sloshing takes place within the IGF vessel.

FLUENT's GAMBIT for 3-D was used for model build-up, as well as for volume meshing. FLUENT's Eulerian Multiphase Model with the segregated solver was used to run transient simulations for flows of water and for the flow of gas bubbles with various sizes within the IGF unit. Additional simulations were employed by applying a UDF (user-defined function) in FLUENT to simulate realistic vessel movements that induced liquid sloshing as a result of ocean wave motion. The meshing cell count of the computer models for a 60-in. diameter by 12-ft. high seam-to-seam vessel, including bottom head and skim bucket, ranged from ~ 70,000 to ~300,000 hybrid elements with total faces of ~170,000 to ~630,000. The primary 3-D geometry for the column flotation cell is shown in Fig. 1. As a simplification, the oily water and gas/water mixture inlets were simplified and the inlet piping, internal supports and coalescence packing materials were neglected.

Fluid flow studies were conducted initially using steady-state simulations to understand contaminated water flow paths. Later, gas bubbles were introduced by using one of FLUENT's most extensive Eulerian multiphase models to predict the gas/water mixture flow pattern using dynamic simulations. Finally, dynamic simulations were conducted using a Volume of Fluid (VOF) multiphase model with a geometric reconstruction scheme to model the fluid sloshing inside the IGF vessel. The CFD simulations were conducted on workstations with dual Intel Xeon processors. Simulation times varied from a few days to several weeks depending upon the complexity of the flow being modeled.

### Physical Testing

The physical test program was carried out at the NATCO-Axsia test facility in Gloucester, U. K. The primary test tank, shown in Fig. 2 was 60-in. in diameter and 15-ft. from top to bottom. Water was recirculated from the tank bottom to the tank top at rates up to 10,000 BHPD. Separately, water could be recirculated to various development models of the gas eductor at rates up to 5,000 BHPD. Water used in the test program included 2% dissolved salts (NaCl) in order to provide for liquid viscosity, liquid density, and a gas bubble size distribution that would be more representative of what would be experienced in actual operation.

As mentioned above, the CFD simulations identified the need to uniformly introduce and distribute gas bubbles of suitable size for effective induced gas flotation (IGF) as a key performance parameter. The simulations further showed the need to generate the gas bubbles within the vessel instead of externally, and to introduce the gas bubbles in a radial pattern. Accordingly, a parallel development effort was instituted to develop the radial eductor. The radial eductor development program, although key to the successful development of a successful vertical column flotation unit, is the subject of on-going patent prosecution and beyond the scope of this paper.

### Results and Discussion

**Oily Water Inlet Design.** Two types of produced water inlet designs were considered: pipe distributor and cyclonic. The pipe distributor suffers from two basic problems in this type of application. First, it does not permit for the disengagement of gas slugs that are often introduced to a flotation cell that is

downstream of a higher pressure separator either directly or through a deoiling hydrocyclone. Although gas solubility varies with temperature, it is not uncommon for the fluid entering a flotation cell or skimmer to have a gas volume fraction (GVF) of 25 to 50%. At these high GVF's, the gas bubbles evolving from produced water can gather in interconnecting piping to form substantial slugs that can upset both vessel level control and oil skimming in a single-cell column flotation unit that is not equipped with a gas disengagement chamber.

The second problem with a pipe distributor was revealed with CFD simulation and confirmed in physical testing. The fluid velocity in a header and lateral distributor tends to push water from the distribution piping in a direction that is not perpendicular to the distributor pipe, see Fig. 3, resulting in a non-uniform fluid distribution within the vessel.

To correct both problems, a cyclonic inlet design was adopted for use in the column flotation unit, Fig. 4. A proprietary TUSTP Consortium GLCC design program<sup>2</sup> was used to size the inlet device for gas slug release while retaining smaller gas bubbles (< 500 microns) for their ability to contribute to the first stage of gas flotation. The cyclonic inlet has the added advantages of contributing to oily contaminant coalescence and flocculation as well as introducing the contaminated water to the flotation cell with a swirl pattern. The swirl pattern discourages the development of stationary vertical circulation cells that would permit oily water to by-pass columns of flotation gas bubbles.

**Gas Bubble Formation and Distribution.** Early column flotation units were equipped with porous metal tube-type gas spargers. The spargers, while effective for this purpose, were difficult to maintain for two reasons. First, typical gas sources available for this purpose contain minute amounts of hydrocarbons and dirt that can plug sparger pores (typically in the 2 to 10 micron range). Second, high gas velocities through the sparger pores tends to dry out brine-wet pore walls, causing the precipitation of otherwise soluble salts and/or scale minerals. Techniques to essentially eliminate both causes of sparger plugging were developed by NATCO and verified in field operations.

CFD simulations showed that properly designed hydraulic eductors could provide a superior bubble pattern for flotation in a column configuration. By controlling the precise geometry of the eductor, gas and recycle water could be distributed over a diameter of several feet. Conventional eductors used in horizontal flotation cells did not have this radial distributive capability. Fig. 5 shows a CFD simulation, later confirmed by physical testing, of a commercially available eductor. The simulation shows the rapid rise of poorly distributed gas bubbles in a column that would by-pass most of the oily water in a column flotation cell. Fig. 6 shows how a radial distribution pattern of water and fine gas bubbles can be designed to disperse gas bubbles widely in a flotation cell. In this case, the gas bubbles are distributed over a diameter that exceeds 5 feet.

**Gas Flotation Mechanisms.** Studies of induced gas flotation have defined three mechanisms for removing oily contaminants from water.<sup>3,4,5</sup> One the coating of gas bubbles

with oil films. The second is the actual, albeit weak, attachment of the hydrophobic contaminant to the gas bubble. This attachment, because it is weak, is temporary and a contaminant may require the assistance of several gas bubbles before it reaches the water surface from which it can be skimmed. This mechanism is likely to be most effective for smaller gas bubbles and smaller contaminants, such as in Dissolved Gas Flotation (DGF). Unfortunately, in actual oilfield operations, these small gas bubbles do not have sufficient time to rise to the surface of an IGF cell.

The third mechanism operable in gas flotation is that of hydraulic drag. With this mechanism, a buoyant particle is carried in the wake of a gas bubble toward the water's surface. Again, the effect is weak and a contaminant will require interaction with several gas bubbles before it is successfully carried to the water surface.

It is clear that all of the above flotation mechanisms will be more effective as the number of interactions with gas bubbles increases. As will be demonstrated below, the opportunity for gas bubble and contaminant interactions increases as gas bubble diameter decreases.

**Gas Bubble Size.** Fig. 7 shows an example of the bubble size distribution that was measured near the outlet of the radial eductor prior to any significant gas bubble coalescence in the flotation cell. As bubbles rise and interact, they will grow both by coalescence and as a result of the reduction of hydraulic pressure. The effective average size of gas bubbles in a flotation cell can be determined if two parameters are known: the increase in liquid height within the vessel when gas is introduced and the gas flow rate through the eductor:

Gas Retention Time = gas volume retained / gas flow rate

Net bubble rise velocity =  
Height of water column/gas retention time

Actual bubble rise velocity is

$V_{\text{rise}} = \text{Net bubble rise velocity} + \text{downward water velocity}$

Effective Bubble Diameter =  
 $\{[V_{\text{rise}} \mu_{\text{water}}] / 1.78 \times 10^{-6} (\rho_{\text{water}} - \rho_{\text{gas}})\}^{1/2}$

Testing at the NATCO-Axasia facility using 2% NaCl brine at ambient temperatures indicated the initial bubble size distribution for the radial eductor's gas bubbles resulted in an "effective" bubble diameter of 250 to 350 microns. This diameter is a function of the produced water's physical/chemical characteristics such as salinity, hardness, surface tension, and temperature (viscosity) and will thus vary from location to location.

The question arises as to how small should gas bubbles be for effective flotation. Fig. 8 shows calculated rise velocities for gas bubbles, oil droplets, and equally sized gas bubbles with attached oil droplets. Based upon a column flotation design parameter of  $\leq 2.0$  ft./min average downward water flow, it can be seen that a gas bubble size greater than about 125 microns is required for gas bubbles to rise up against the downward flowing water. An oil droplet would need to be

300 microns in diameter to rise against this same velocity on its own. By associating with a gas bubble, however, an oil droplet of 160 microns can be floated.

Fig. 8 illustrates two points. First, the importance of providing both opportunity and chemistry for inducing the coalescence and/or flocculation of oily contaminants in order for a flotation cell to effectively clean produced water. Second, the need for properly sized gas bubbles in order for induced gas flotation to perform successfully.

The importance of small gas bubbles for flotation efficiency can be illustrated by calculating a parameter referred to as the Sweep Factor.<sup>3</sup> The Sweep Factor is the number of times per unit time (e.g., number of times per minute) a given volume of water is swept by a gas bubble. The larger the Sweep Factor, the higher the probability of successful gas bubble & contaminant interaction, thus the higher the flotation efficiency. The Sweep Factor is defined by the following:

$$\text{Sweep Factor (min}^{-1}\text{)} = (A_{\text{gas}} \times F_{\text{gas}}) / A_{\text{cell}}$$

Where

$A_{\text{cell}}$  = cross sectional area of flotation cell (ft<sup>2</sup>)

$F_{\text{gas}}$  = gas flow rate (ft<sup>3</sup>/min)

$A_{\text{gas}}$  = total cross sectional area of gas bubbles per unit volume (ft<sup>2</sup>/ft<sup>3</sup>)

If gas is flowing into an IGF unit at the rate of 1 ACF/BBL of produced water capacity, the Sweep Factor as a function of bubble diameter is as follows:

Bubble Diameter (microns)	Sweep Factor (min <sup>-1</sup> )
100	1634
120	1362
200	817
300	545
400	408

These numbers clearly indicate the advantage of introducing smaller gas bubbles into a flotation cell. However, fluid flow considerations, as discussed above, serve to limit the minimum size that can be allowed in a flotation cell. In column flotation, the bubble size introduced must be as small as possible while maintaining the required net upward rise velocity for the gas bubble.

#### Skimming Contaminants from a Column Flotation Cell.

When installed on a floating platform, an IGF vessel will experience considerable movement. This results in water sloshing within the vessel that can seriously disrupt the removal of floating contaminants from the unit. Several CFD simulations using a variety of skimming configurations were studied with little success in the control of the actual fluid sloshing. This was attributed to the fact that, although sloshing can be severe, the actual volume of water that moves

to generate this sloshing is small, making it difficult or impossible to control with conventional baffling.

CFD simulations indicated that the most effective method would be to equip the column IGF unit with a two stage skimming system as illustrated in Fig. 9. In the first stage, water and oil slosh into shallow buckets that effectively dampen water sloshing. Water can leave these buckets via bottom holes, but floating contaminants are retained. The contaminants can then be skimmed into the oil bucket for retention prior to their being removed from the vessel.

**Field Performance.** The performance data of a 10,000 BWPD VersaFlo™ column flotation unit based upon the above described design principles is illustrated in Table 1. The unit is installed on a spar and experiences considerable movement due to the long moment arm between the spar's center of rotation and the point at which the IGF unit is installed. Nevertheless, with the proper application of chemistry to assist with contaminant coalescence and flocculation, the quality of the produced water remains well within permissible discharge limits.

## Summary and Conclusions

Computational Fluid Dynamic simulations are an effective tool for assisting with the development of new technologies for oilfield application. Performance limitations with existing designs can be identified and rectified by the use of CFD simulations. Several CFD simulations can be performed at less expense and in a shorter time than required by physical testing. However, validation of CFD simulation model results by physical testing is essential.

By using CFD simulations and follow-up physical testing, fluid flow path and gas bubble distribution issues for existing column flotation technologies could be identified and the means to rectify these deficiencies developed. The development of the new design for vertical column flotation technology relied on this methodology. The excellent field performance of the new column flotation design has validated both the technology itself and the methods used to develop it.

## Acknowledgments

The authors wish to acknowledge Mr. Robert Curcio, Sr. Vice President of Technology, NATCO Group, for his support and encouragement for this paper. We also gratefully acknowledge the contributions of Mr. Neville Lange for his efforts in the development of the radial eductor, a critical component of the VersaFlo™ technology. And we also thank and express our appreciation to Mr. Aaron Davis and the Kerr-McGee Corp. for their willingness to install and test the newly developed vertical column flotation technology.

## References

1. Frankiewicz, T., and Lee, C.M., Using Computational Fluid Dynamics Simulation to Model Fluid Motion in Process Vessels on Fixed and Floating Platforms, SPE 77494, 2002.
2. See the web site [www.TUSTP.org](http://www.TUSTP.org).

3. Byeseda, J. J., and Sylvester, N. D., Oil/Water Separation by Induced-Air Flotation, SPE 7886, 1980.
4. Strickland, W. T. Jr., SPE 7805, 1980
5. Oliveira, R. C. G., Gonzalez, G., and Oliveira, J. F., SPE 50767, 1999.

## Nomenclature

$\rho$  = density (kg/m<sup>3</sup>)

$\mu$  = viscosity (cP)

V = velocity (ft/min)

A = cross sectional area (ft<sup>2</sup>)

F = gas flow rate (ft<sup>3</sup>/min)

## SI Metric Conversion Factors

in	x 2.54	E-02 = m
ft	x 3.048	E-01 = m
ft <sup>2</sup>	x 9.29	E-02 = m <sup>2</sup>
ft <sup>3</sup>	x 2.83	E-02 = m <sup>3</sup>
bbls	x 1.59	E-01 = m <sup>3</sup>

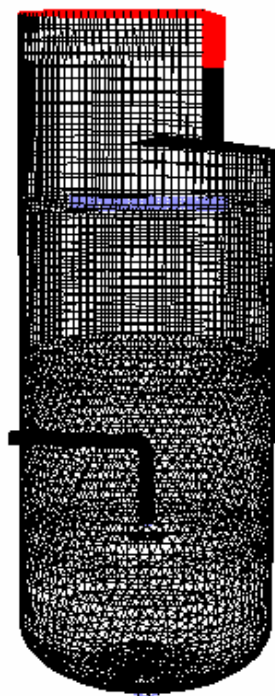

**Figure 1.** The meshing is shown for the the CFD simulation model used in the development of vertical column flotation. The model contained 148,161 cells with 342,550 faces. Details were changed from run to run as the technology was developed.

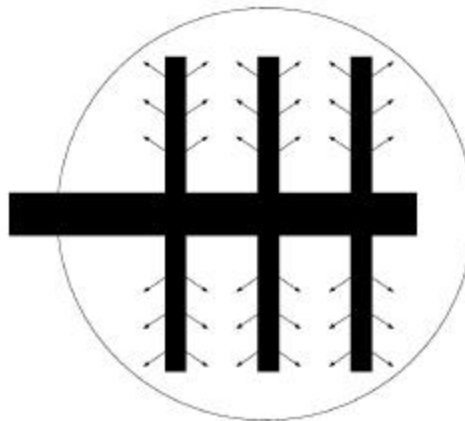

**Fig. 3.** Fluid exits a pipe distributor at an angle controlled by the fluid velocity in the pipe and not in a perpendicular manner. This can lead to non-uniform distribution of fluids in a vertical vessel, making pipe distributors not suitable for use with column flotation.



**Fig. 2.** The 5-ft diameter by 15-ft tall tank at the NATCO-Axsis facility in Gloucester, U. K. that was used to validate and extend the results of CFD simulations for the vertical column flotation technology development program.

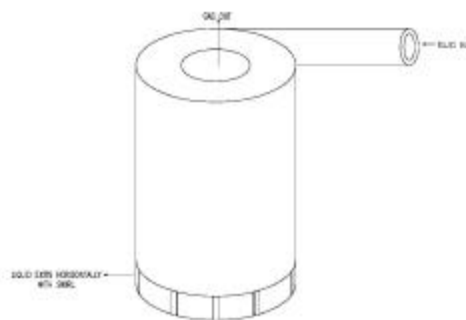

**Fig. 4.** The cyclonic inlet eliminates gas slugs that can disrupt skimming in a column IGF unit and releases water in a horizontal, distributive pattern with swirl to spread inlet water over the full cross section of the vessel.

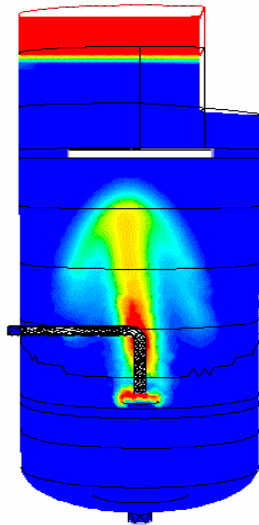

**Fig. 5.** A CFD simulation shows that a commercially available eductor design would be ineffective at distributing gas within a vertical column flotation cell. This was later verified by physical testing at the NATCO-Axsia U.K. test facility.

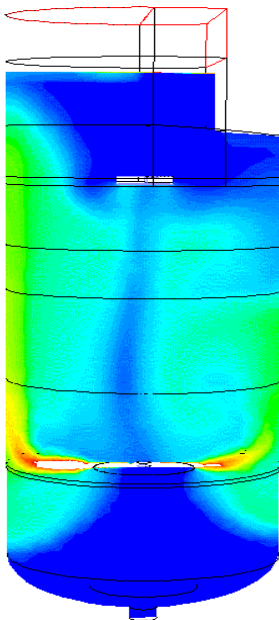

**Fig. 6.** By using a radial distribution pattern, gas bubbles can be distributed over a large area in a column flotation cell. The area over which gas can be distributed is controlled by the geometry of the radial eductor assembly.

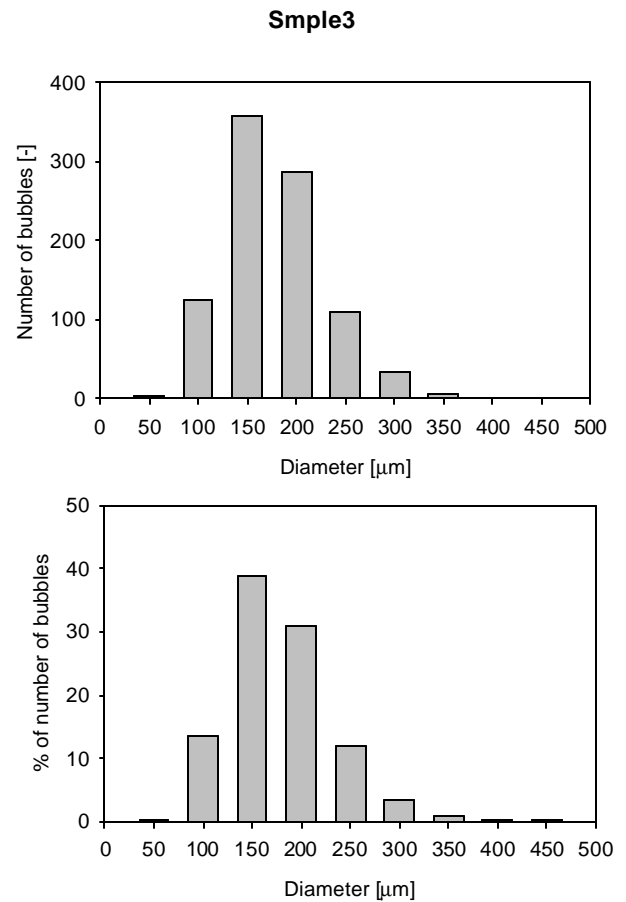

**Fig. 7.** Gas bubble size distribution from the radial eductor shows a median bubble size near 150 microns.

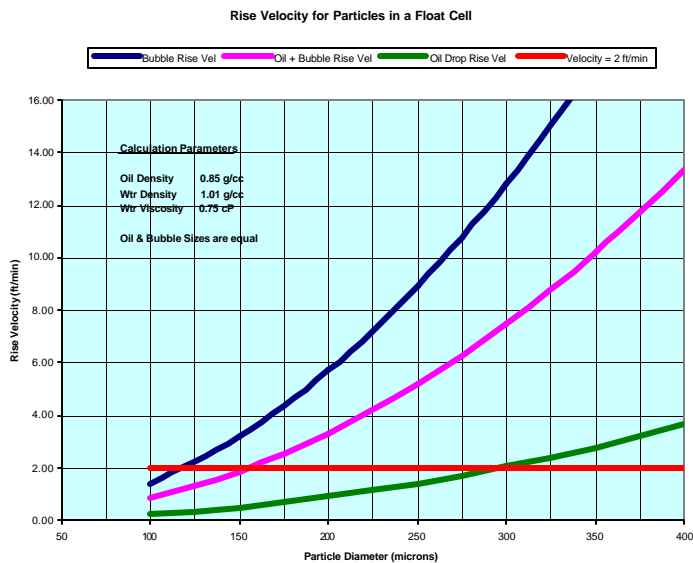

**Fig. 8.** Calculated rise velocities for gas bubbles, oil droplets, and oil droplets with associated gas bubbles. Note the minimum bubble size for rising against a 2 ft/min. downward water flow velocity is about 120 microns.

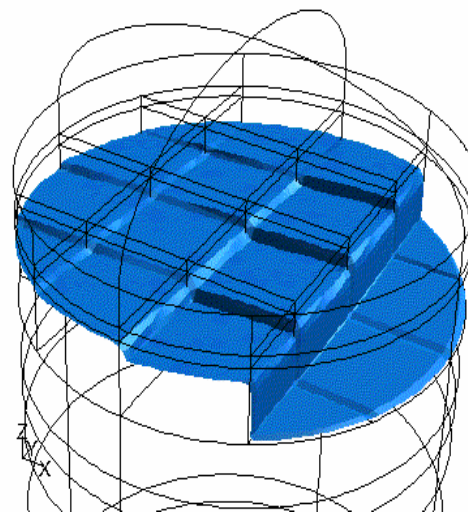

**Fig. 9.** A 2-stage skimming arrangement is used in the vertical column flotation unit to control skimming when liquid is sloshing due to vessel movement on a floating platform.

**TABLE 1.** FIELD PERFORMANCE DATA IS SHOWN FOR A 10,000 BHPD VERSAFLO™ COLUMN FLOTATION VESSEL. THE UNIT IS INSTALLED ON A SPAR IN THE GULF OF MEXICO. DATA WERE ACQUIRED DURING SEA STATES THAT VARIED FROM 5-FT. TO 10-FT WAVE HEIGHTS.

<u>Date</u>	<u>Inlet TOG</u>	<u>Outlet TOG</u>
02-03	52 mg/liter	27 mg/liter
02-03	48	19
02-03	37	13
10-04	47	15
10-04	55	23

TOG = Total Oil and Grease as determined by EPA 1664